

Micro Automotive Plug In / PCB Power Relay

PC782

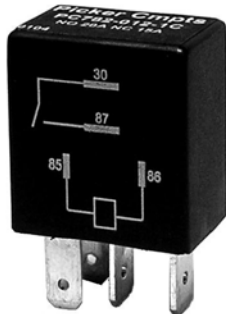

FEATURES

- Micro size plug-in design
- 1 A, 1 B and 1 C contact forms available
- Contact switching capacity up to 90 Amps
- 30 Amps continuous carrying capacity
- Up to 125 degrees C operating temperature
- PC Board version available
- Sockets available from Picker Components
- Internal Diode or Resistor available

CONTACT RATINGS

| Contact Form | 1 Form A, 1 Form B or 1 Form C | |
|-------------------------|-------------------------------------|-----------------|
| | Normally Open | Normally Closed |
| Max Switching Current | Make 90 Amps | Make 20 Amps |
| | Break 30 Amps | Break 15 Amps |
| Max. Switching Voltage | Current Dependent, see curve page 2 | |
| Max. Continuous Current | 30 Amps | 20 Amps |
| Minimum Load | 0.1 A @ 12 VDC | |

CONTACT DATA

| | | |
|----------------------------|------------|--|
| Material | | AgNiO 15 (Silver Nickel Oxide 15%) AgSnOInO (Silver Tin Oxide Indium Oxide) |
| Initial Contact Resistance | | 100 milliohms max @ 0.1A, 6VDC |
| Service Life | Mechanical | 1 X 10 ⁷ Operations |
| | Electrical | 2 X 10 ⁵ Operations |

CHARACTERISTICS

| | |
|---------------------------|---|
| Operate Time | 9 ms. typical |
| Release Time | 7 ms. typical |
| Insulation Resistance | 100 megohms min, at 500VDC, 50%RH |
| Dielectric Strength | 500 Vrms, 1 min. between coil and contacts |
| Shock Resistance | 20 g, 11ms, functional; 200 g, destructive |
| Vibration Resistance | DA 1.27 mm, 10 - 40 Hz; 40-70 Hz: 5 g; DA 0.5mm, 70-100 Hz; 100-500 Hz: 10 g. |
| Drop Resistance | 1 Meter height drop on concrete |
| Power Consumption | 1.6 W approx. |
| Ambient Temperature Range | -40 to 125 degrees C operating, -40 to 155 storage |
| Weight | Plug-In: 14 grams; PCB: 12 grams approx. |

ORDERING INFORMATION

| | | | | | | |
|--------------------|----------------------------------|-----|----|-----|---|----|
| Example: | PC782 | -1C | -P | -12 | S | -R |
| Model | | | | | | |
| Contact Form | 1A, 1B or 1C | | | | | |
| Mounting Version | Nil: Plug-IN; P: PCB | | | | | |
| Coil Voltage | | | | | | |
| Enclosure | C: Dust Cover, S: Sealed Case | | | | | |
| Parallel Component | Nil: None; D: Diode; R: Resistor | | | | | |

COIL DATA

| Coil Voltage | Resistance ohms $\pm 10\%$ | | Nominal Operate Voltage Max. | Allowable Voltage Max. | | Nominal Release Voltage Min. |
|--------------|----------------------------|----------|------------------------------|------------------------|----------|------------------------------|
| | 1 Form A & B | 1 Form C | 1 Form A, B & C | 1 Form A & B | 1 Form C | A, C, U, W |
| 6 | 32 | 25 | 3.6 | 10.4 | 9.2 | 0.6 |
| 12 | 123 | 97 | 7.2 | 20.4 | 18.1 | 1.2 |
| 24 | 483 | 384 | 14.3 | 40.4 | 36.0 | 2.4 |

Dimensions in Inches (millimeters)

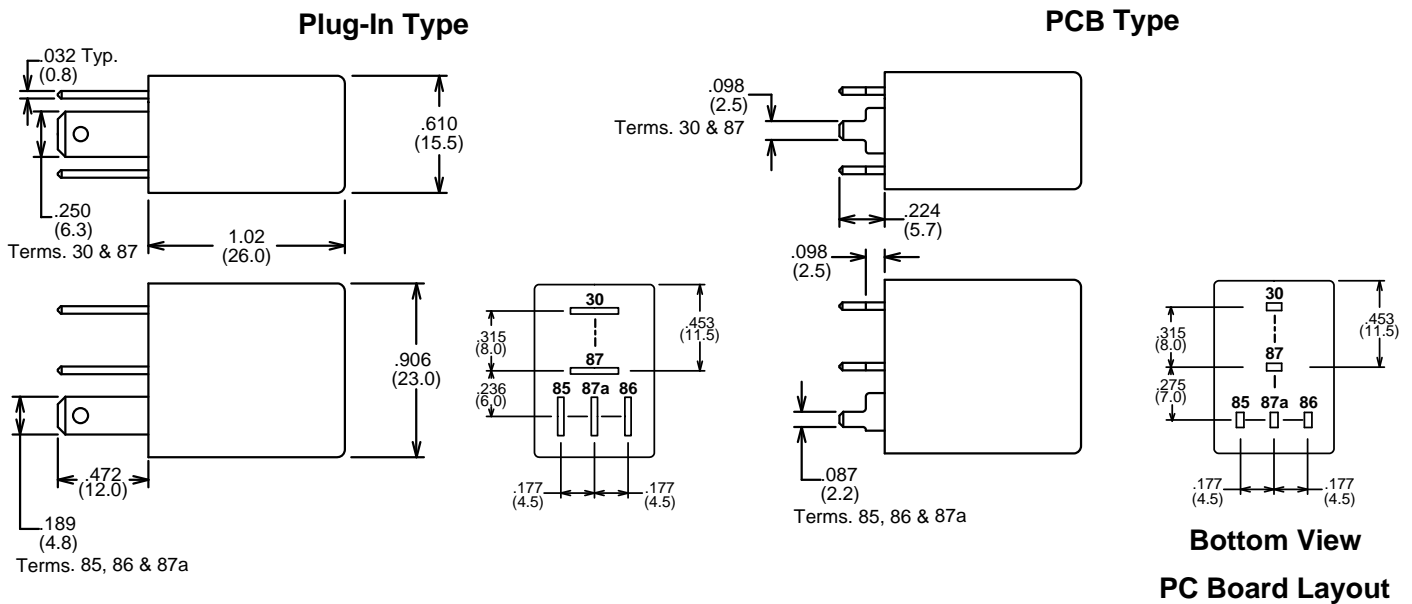

Wiring Diagram

Notes:
 Contact Form C shown
 On Contact Forms A & B Unused Pins are Omitted
 Tolerances $\pm .010$ unless otherwise noted
 Maximum make current refers to inrush of a lamp load
 Make current of 120 Amps permissible with AgSnInO contacts
 In 85 degree C ambient reduce maximum coil voltage to 72%



3220 Commander Drive, Suite 102, Carrollton, Texas 75006

Sales: Call Toll Free (888) 997-3933 Fax (818) 342-5296 email: pickerwest@sbcglobal.net URL: pickercomponents.com